



State-of-the-art solutions

Demag KBK – the modular light crane system



One system to meet all your needs

From simple workshop cranes to highly complex material flow systems; with our Demag KBK light crane system, we can meet all your needs quickly and efficiently. The components of our modular construction kit system can be combined to create individual suspension cranes, suspension monorails, pillar and wall-mounted slewing jib crane solutions. Demag KBK installations can also be easily integrated into any production infrastructure – and modified at any time.

VERSATILE AND FOR SPECIFIC NEEDS

The modular construction kit system offers a high level of flexibility. Installations can not only be built with a combination of steel and aluminium profile sections, but existing installations can also be quickly and easily extended and additional components can be integrated. The system includes many matching modular parts for solutions to meet specific requirements.

SAFE, SIMPLE AND RELIABLE HANDLING

Rapid handling and, at the same time, precise and effortless positioning of your loads provide for efficient processes and improve your productivity. The KBK system is ideally suited for complex handling equipment as used in series production lines, such as in the automotive industry.

ERGONOMIC OPERATION

Demag KBK now makes load handling easier than ever before, requiring only little force for simple load handling – both with steel and aluminium profile sections. Reduced loads result in lower absenteeism due to illness and greater employee satisfaction.

RELIABLE

With more than 60 years of experience with light crane systems, our Demag KBK crane construction kit provides for safe and reliable material flow in virtually all industries around the world. Made of standardised products manufactured in large series, our components offer high operating reliability and a long service life.

DEMAG KBK:

- World's largest selection of system components
- Wide range of applications
- Optimum workplace design
- High productivity and efficiency
- Rugged design requires little maintenance
- Broad load capacity range up to 3,200 kg
- Maximum strength for a low deadweight
- Large distances between suspensions and span dimensions
- Can be connected to all building superstructures
- Quality made in Germany



Maximum flexibility
FOR MANY APPLICATIONS

Safe and reliable area-serving material handling



KBK SINGLE AND DOUBLE-GIRDER SUSPENSION CRANES

Demag KBK suspension cranes can be easily moved by hand, which also enables bulky and heavy workpieces to be handled safely and precisely. Since they are suspended from a superstructure, such as roof beams, steel girders or concrete ceilings, they require no additional floor space. Both individual workstations or complete production and storage areas can be fully served with overhead systems. Available in steel or aluminium.



FURTHER DETAILS

- Smooth-running, unhindered operation thanks to flexible suspension of the crane runways in connection with articulated attachment of crane girders
- Customer-specific configuration to meet individual requirements
- Designed for optimum height and can be adapted to building structure or process requirements
- Cranes can also operate on runways that are not parallel
- Very large spans when suspended from more than two crane runways
- Cranes can have overhangs of up to 2.5 m, depending on configuration, load and profile sections
- Electric travel possible for long and cross-travel motions (recommended for large spans or heavy loads)
- Load capacities up to 3,200 kg (steel) or 2,000 kg (aluminium)



41579-19

- Profile section rail
- End cap with buffer
- Suspension
- ┆ Bolted connection
- Travelling hoist
- Latching device
- Travel drive
- ▤ Diagonal stiffener

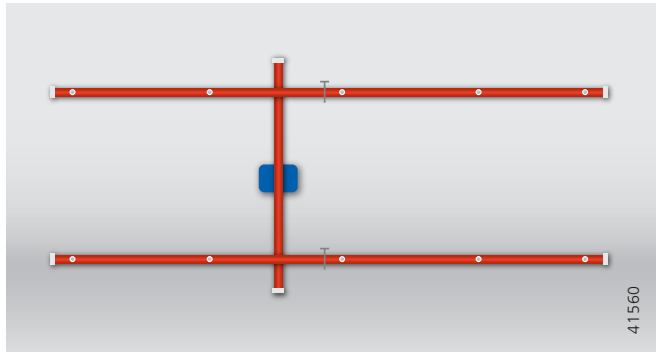

41560

Single-girder suspension crane, parallel track

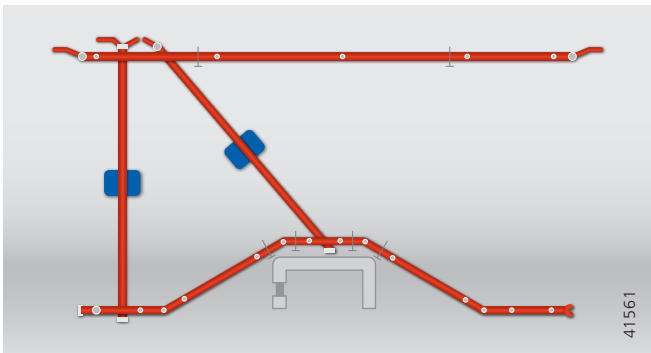

41561

Single-girder suspension crane, angled track

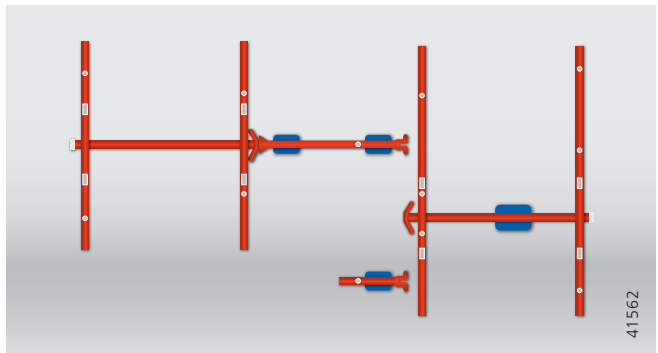

41562

Interlocking single-girder suspension cranes

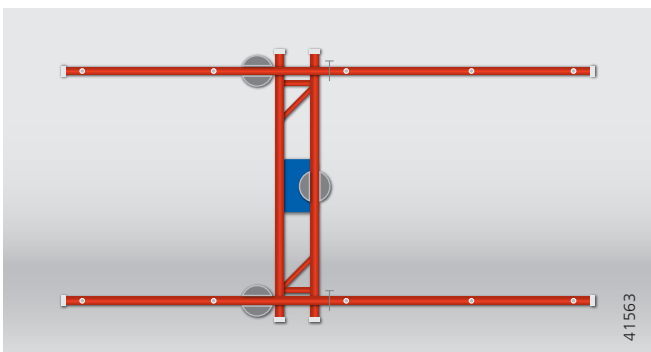

41563

Double-girder suspension crane

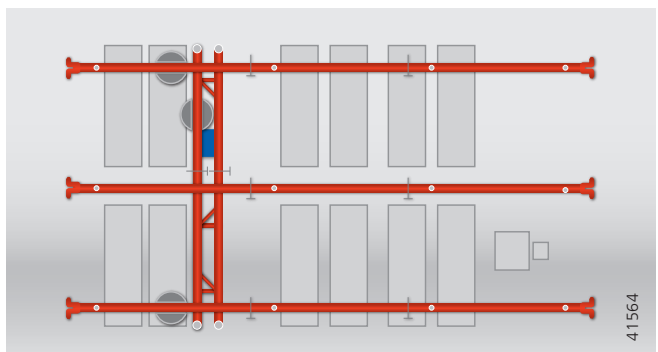

41564

Double-girder suspension crane, on 3 runways



KBK steel profile sections

4 INTEGRATED CONDUCTOR LINE

Safe and space-saving power supply via profile sections with integrated conductor line:

- Additional headroom gain
- No risk of collisions (e.g. with forklifts) thanks to lack of cables
- Additional external power supply fittings not required, which minimises assembly times and costs

5 DEMAG KBK TROLLEYS

Excellent smooth-running performance and minimum rolling resistance over their entire service life:

- Quiet and smooth operation thanks to plastic wheels that are mounted in anti-friction bearings and lubricated for life
- Maintenance-free travel wheels with effective shock absorption
- Compact design with low deadweight

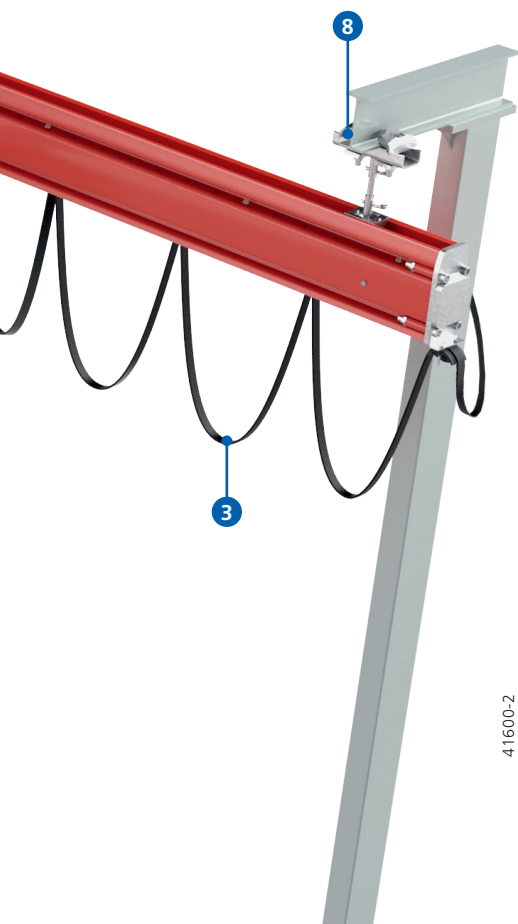

KBK Aluline profile sections

6 TRAVEL DRIVES

Recommended for use with heavy loads and complex installations:

- Electric and pneumatic variants
- Large friction wheels that have a high friction coefficient ensure reliable transmission of drive torque
- High traction: connection between travel drive and track does not depend on position and weight of the load
- Quiet-running drives

7 DEMAG KBK II-H JOINT CONNECTION

Planning and project engineering can be simplified by the completely rigid rail connections on KBK II-H profile sections:

- The rail joint can be subjected to a full load – regardless of the position of the track suspension
- No additional steelwork required
- Efficient solution with short delivery times since straight sections in special lengths are largely avoided
- Fast track connection assembly thanks to self-retaining nuts that are secured against turning

8 DEMAG KBK SUSPENSIONS

Secure attachment with articulated suspensions:

- Significant reduction of horizontal forces in roof and support superstructures
- Impacts and noise minimised by plastic shells in the ball joints
- Exact alignment down to the millimetre thanks to track height adjustment with threaded suspension rods
- Flexible mounting arrangements for connection to various superstructures
- Low maintenance requirement

Variable working area, efficient use of space

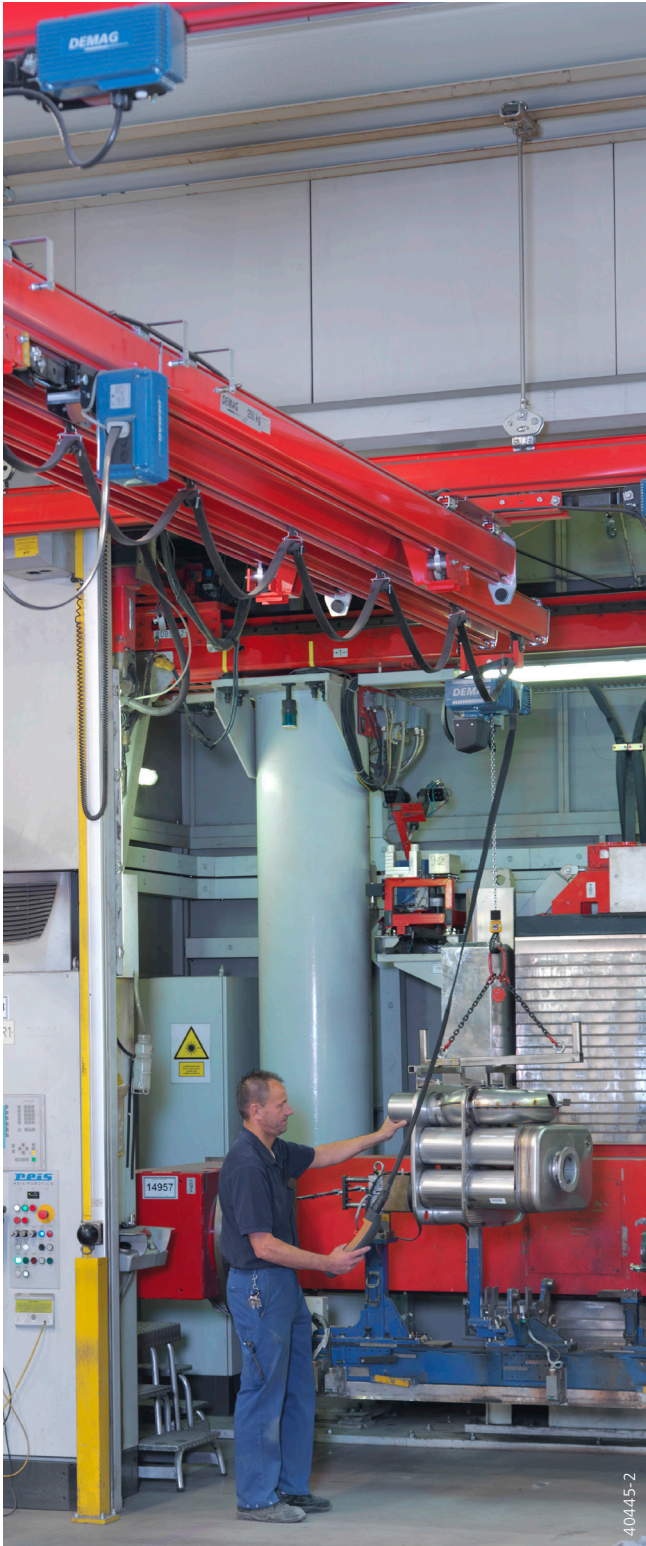

DEMAG KBK EXTENDING CRANES

These cranes can also be used for precisely lifting and positioning loads outside the area covered by the crane runway. A valuable benefit: their operating range can be extended to serve almost inaccessible areas, such as between pillars and columns. Available in steel or aluminium.

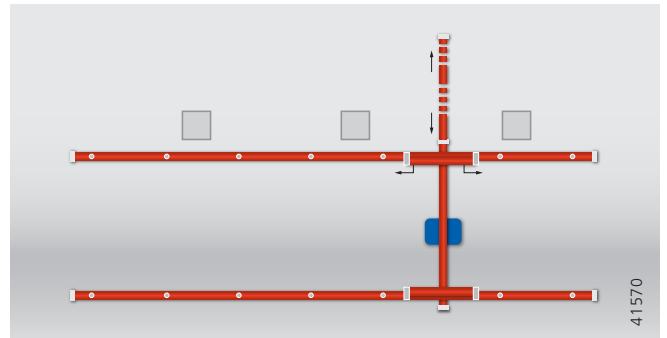

Single-girder extending crane

- Profile section rail
- End cap with buffer
- Suspension
- ⊥ Bolted connection
- Travelling hoist

FURTHER DETAILS

- Extending cranes consist of a fixed section and a crane section that can be extended
- High versatility, since the girders can be extended to one or both sides
- Extensions up to 2.5 m in length possible (depending on configuration, load and KBK profile section)
- Particularly ergonomic and efficient operation thanks to lockable travelling hoist, which can save time for the operator
- Push or electric travel (long-travel, extending, cross-travel motions)



Overhead solutions for complex handling tasks

DEMAG KBK CRANES FOR HANDLING EQUIPMENT

Crane installations or tracks can be used as carrier systems for handling equipment (e.g. manipulators or lifting devices) for rigid load handling and bolting applications. They are optimised to accommodate kick-up forces and torques. Their low deadweight, high positioning accuracy and fast operating speeds form the basis for optimum ergonomics and efficient workplace design. Available in steel or aluminium.

FURTHER DETAILS

- Manual or power-driven travel motions
- Arrangements for electric, pneumatic or mixed power supply

Overview of Demag KBK Ergo components: KBK extending crane and double-girder suspension crane for handling equipment

Ergonomics all along the line:
Demag KBK Ergo can be used to
implement tailored solutions to carry
manipulators and lifting devices
when kick-up forces need to be
safely accommodated.

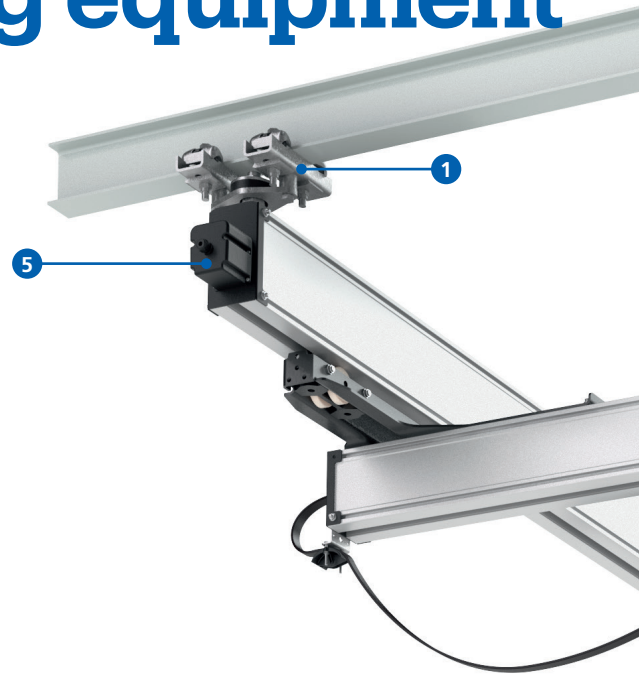

1 DEMAG KBK ERGO SUSPENSIONS

Safely accommodate kick-up forces:

- Rigid design to transfer forces to the superstructure via rubber damping elements
- Height adjustment with millimetre precision
- Ideally suited for applications with manipulators, lifting devices, extending cranes or offset loads

2 DEMAG KBK ERGO END CAPS

Easily installed track end cap:

- Precise damping elements for every application: rubber or cellular foam buffers and shock absorbers

3 DEMAG KBK ERGO TROLLEYS

Optimum travel characteristics and high positioning accuracy also at high operating speeds:

- Smooth travel thanks to lateral guide rollers fitted as standard
- Counter-pressure roller to accommodate kick-up forces, can be adjusted via eccentric fitting
- Universal bolted connection to attach customer-specific handling solutions

4 DEMAG KBK ERGO CRANE END CARRIAGES

Special end carriage design offering high system rigidity:

- Light-weight design
- Improved positioning accuracy
- Optimum load distribution
- Equipped with Ergo trolleys

5 DEMAG KBK ALULINE POWERFEED END CAP

- Powerfeed arrangement for KBK Aluline A18-R, A22-R and A28-R profile sections with internal conductors

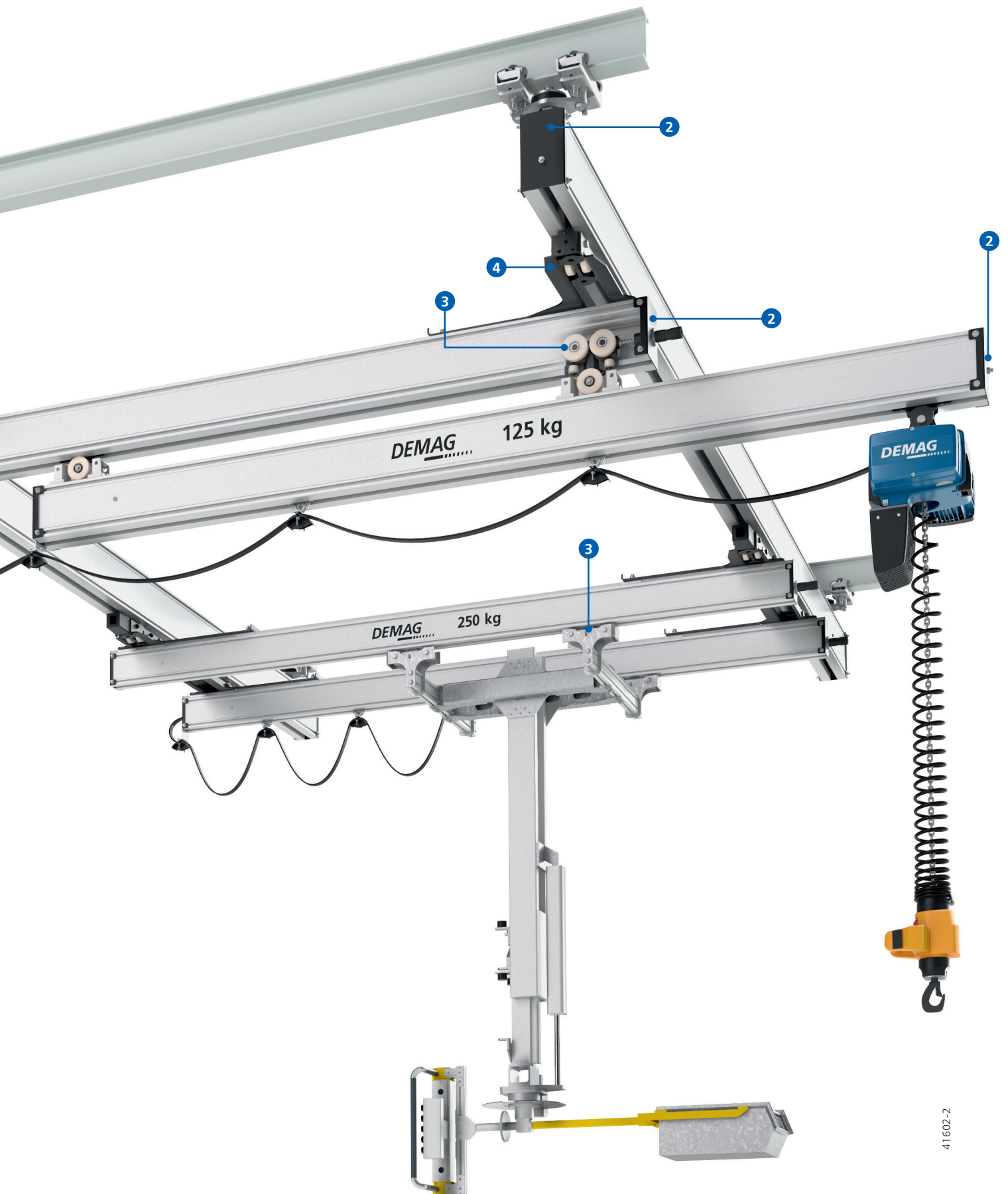

Tailored solutions for linear overhead handling



DEMAG KBK SUSPENSION MONORAILS

Suspension monorails from our KBK light crane system give you the certainty of solutions tailored to meet your specific requirements for linear, overhead handling. Their special strengths are to be found in their many options. Thanks to many system components, such as straight and curved sections, track switches, drop sections or turntables, our proven Demag KBK steel profile sections ensure that your specific requirements can be met for handling loads weighing up to 3,200 kg.

FURTHER DETAILS

- Simple straight tracks (also in aluminium up to 2,000 kg)
- Straight double-rail tracks, e.g. as carrier systems for rigid handling equipment, such as manipulators (also in aluminium up to 2,000 kg)
- Semi- or fully automated circuits/monorails with many branch tracks – for complex material flow requirements
- Connections between linear and area-serving transport systems: transfer sections to adjacent suspension cranes using latching devices
- Equipment to overcome different height levels
- Push or electric-travel trolleys

- Profile section rail
- End cap with buffer
- Suspension
- | Bolted connection
- Travelling hoist
- Travel drive
- ⌋ Track switch
- Drop section
- Turntable

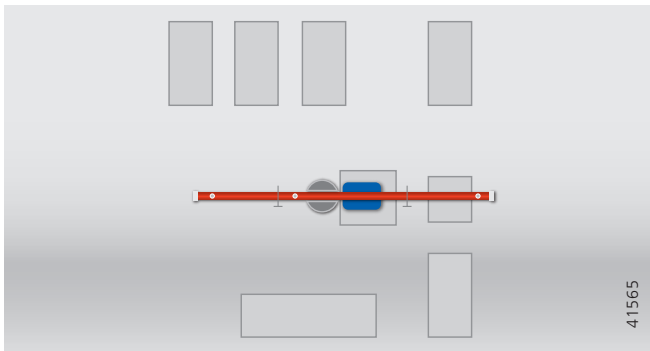

Straight suspension monorail

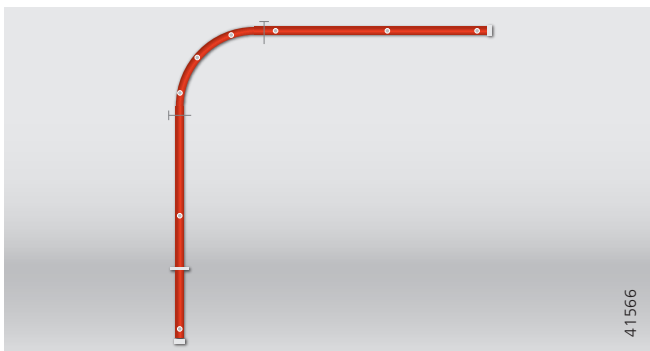

Suspension monorail with 90° curve

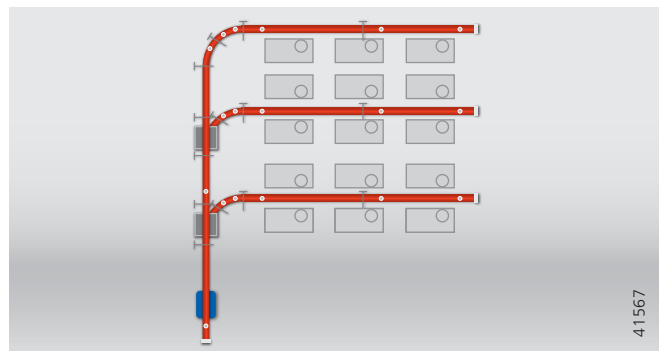

Suspension monorail with track switches

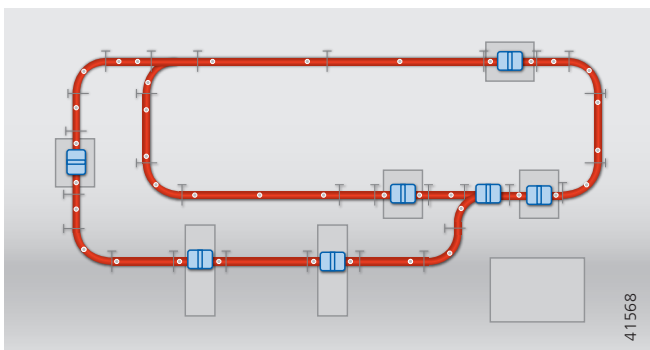

Monorail circuit with drop sections

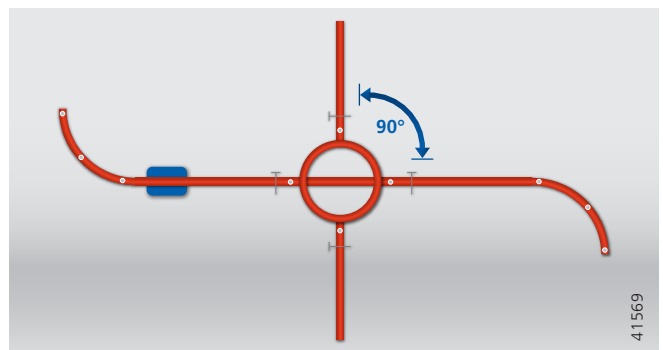

Suspension monorail with turntable

Overview of components: Demag KBK suspension monorail

A wide range of components enables you to adapt the layout precisely to meet the material flow and structural requirements of your workshop and gives you maximum flexibility for planning your suspension monorail.

1 STEEL SUPPORT SUPERSTRUCTURE

Portal steel superstructure:

- Support system can also be used wherever workshop ceilings and roof structures cannot bear loads
- High flexibility for planning and configuration

2 CURVED SECTION

Precisely engineered solutions for transporting loads through curves

- Angles between 10° and 90° possible

3 TURNTABLE

Compact design for changing direction through 90°:

- Integrated mechanical locking devices prevent trolleys from entering or leaving the turntable section while it is turning
- Manual or electric options to change the direction of travel
- Can be integrated into semi- or fully automatic control systems

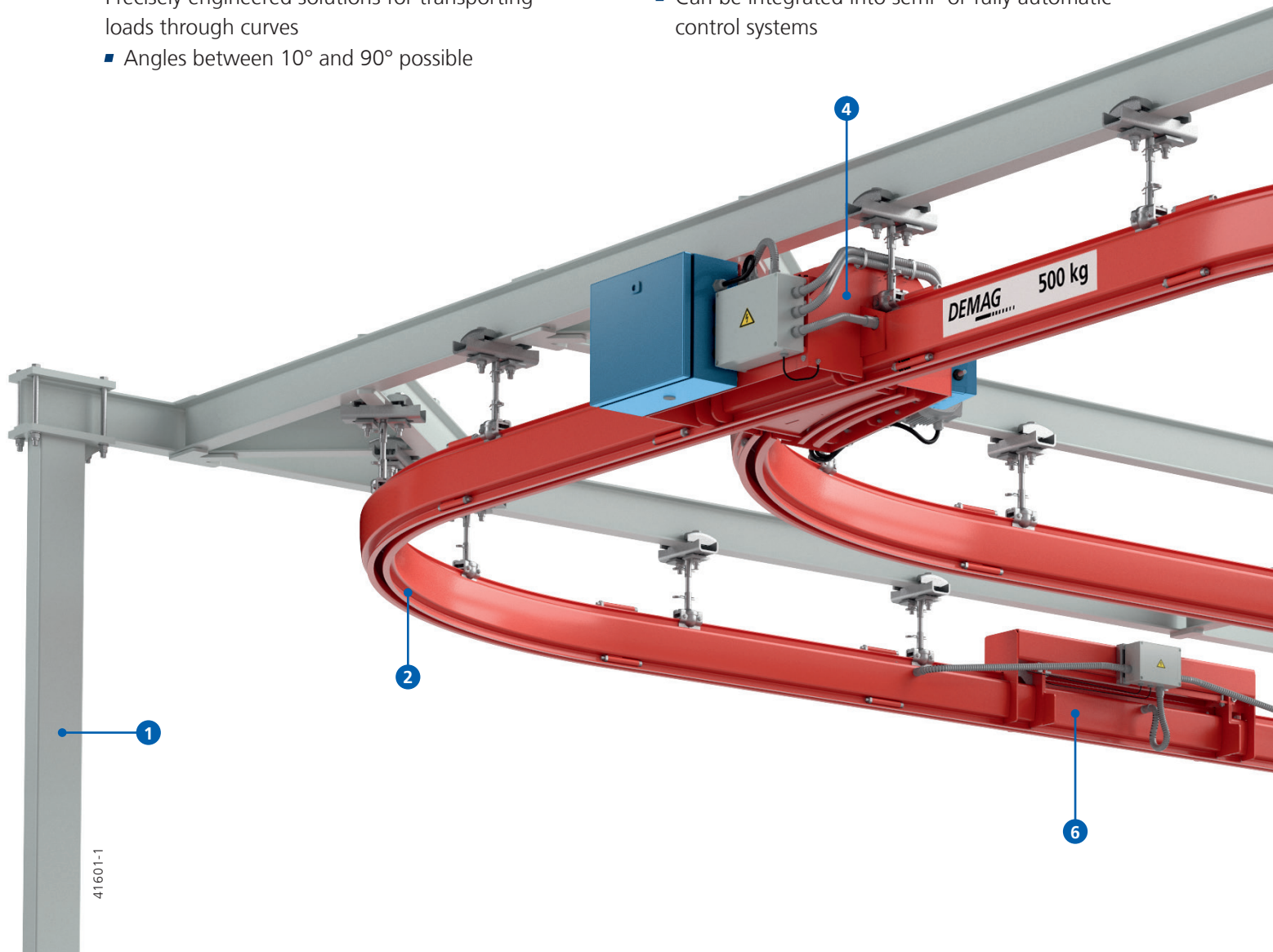

4 TRACK SWITCH

For separating and merging tracks:

- Enclosed, compact design
- Manual, electric or pneumatic options to change the direction of travel
- Can be integrated into semi- or fully automatic control systems

5 TRAVELLING HOIST

Electric travel with friction-wheel travel drive:

- Precise positioning and fast handling

6 MAINTENANCE RAIL WITH PULL-OUT SECTION

Saves time and costs for maintenance and repairs:

- Simple installation and removal of travel units
- Pull-out section can be used as an assembly opening
- A fully loaded trolley can travel through it when closed, allowing integration at the optimum position in the track

7 INTEGRATED CONDUCTOR LINE

Power supply arrangement for suspension monorails also with complex layouts:

- Up to eight conductors integrated in the profile section
- Reliable power supply without any external interference contours

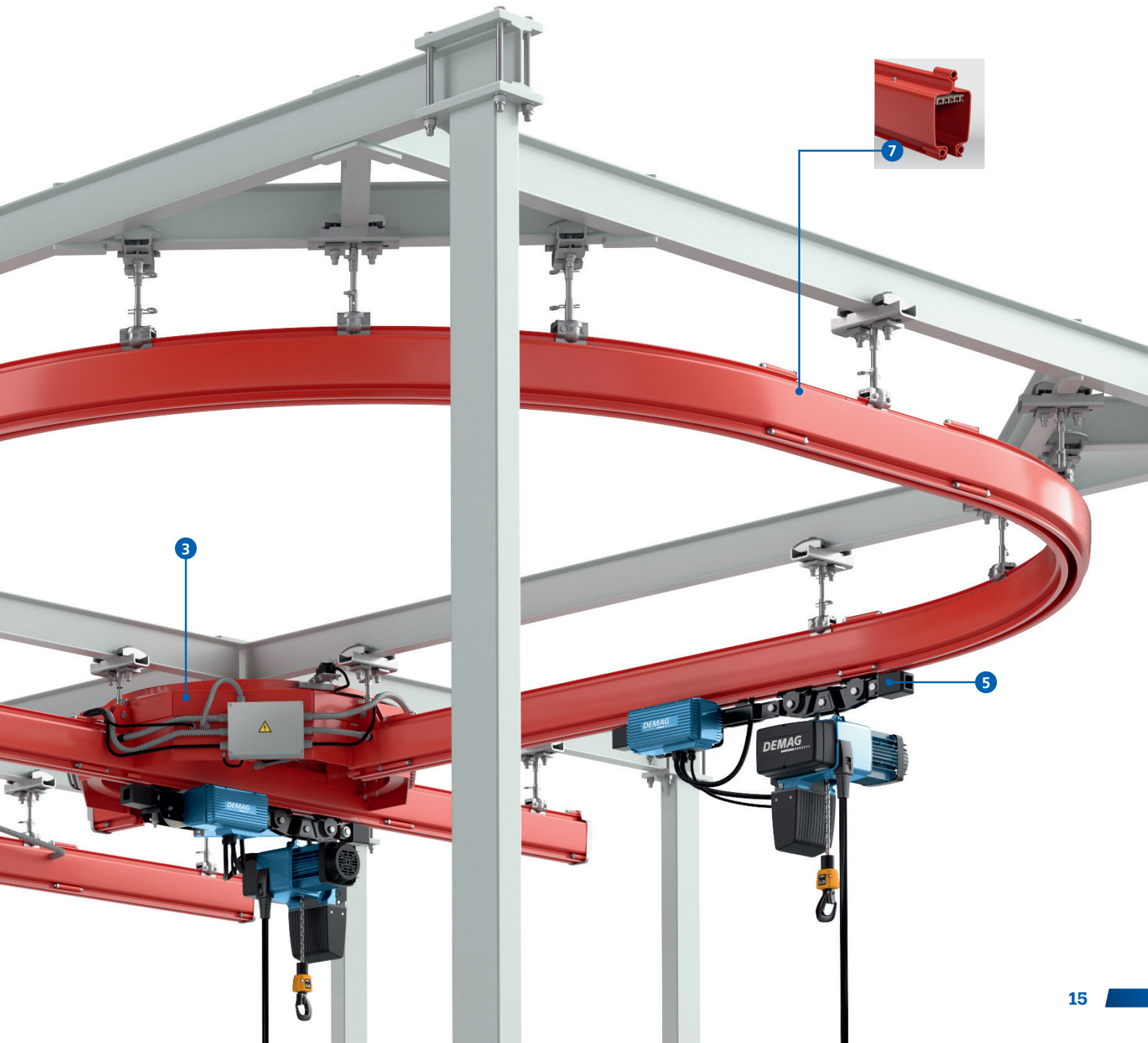

Specialised handling for stores

DEMAG KBK STACKER CRANES

Unit loads weighing up to 500 kg can be transported and stored with ease – load handling attachments can be simply adapted to the type of load. All tasks can be performed in one operating cycle. Additional equipment such as ladders or order-picking trolleys is not needed.

FURTHER DETAILS

- Combination of KBK double-girder suspension crane and special stacker trolley
- Can be turned through a range of 360°, by hand
- Long and cross travel always by hand, lifting motion via electric chain hoist



39958-2



40562-5-1

Mobile workplace units

DEMAG KBK PORTAL CRANES

For all applications wherever a permanent crane cannot be installed. Can be easily moved and manoeuvred in any direction – ideal for repair and assembly work or loading and unloading operations.

FURTHER DETAILS

- Up to 1,000 kg load capacity with KBK hollow profile section
- Up to 3,200 kg load capacity with I-beam girder
- Infinitely adjustable distance between legs

Efficient workplace design





DEMAG KBK SLEWING JIB CRANES

Effective workplace crane solution to serve a specific working area. Demag slewing jib cranes can be installed virtually anywhere for handling loads weighing between 80 and 10,000 kg. They ensure that all types of workpieces can be lifted quickly and easily, transported gently and deposited precisely, providing handling performance at machine tools and assembly stations, as well as in outdoor storage yards and on loading ramps.

FURTHER DETAILS

- Wall-mounted slewing jib cranes
- Pillar-mounted slewing jib cranes (also available with 2 jibs)
- Pillar-mounted slewing cranes with 360° slewing range
- Manual or electric slewing motion

See brochure 208 755 44 for detailed information.

Demag hoist units, control and load attachment

Demag hoist units are available with a wide range of load capacities, lifting speeds and features.

They can also be used with a broad selection of controls and load handling attachments. Together, these components can provide valuable ergonomic relief for your employees and, at the same time, maximum safety and reliability wherever they are used.

COMPREHENSIVE STANDARD FEATURES FOR DEMAG CHAIN HOISTS:

- High level of safety thanks to 24 V contactor control and operating limit switches
- Flexibility thanks to two sizes of suspension bracket
- Simple commissioning thanks to plug connections
- Gearbox, brake and slipping clutch maintenance-free for up to 10 years
- Smooth and fast load handling with two lifting speeds
- Infinitely variable speed control option for even more precise handling
- Elapsed operating time counter and diagnostics interface provide information on the operating status



DEMAG DC CHAIN HOIST WITH PENDANT CONTROLLER

- Fatigue-free operation
- Convenient handling thanks to ergonomic housing design
- Comfortable working posture thanks to rapid height adjustability without any need for wiring
- Highly rugged design

DEMAG DCM-PRO MANULIFT AND CHAIN HOIST WITH ROCKER SWITCH

- Ergonomic single-handed load handling
- The chain hoist can be operated while the operator guides the load
- For right-hand and left-hand operation
- Quick-change coupling enables a wide variety of load handling attachments to be connected

DEMAG DC-PRO CHAIN HOIST WITH WIRELESS CONTROL

- The operator can vary his distance to the load for even more safety
- High versatility and availability
- Interference-free radio transmission
- Simple, wireless log-on of the hand-held transmitter
- Stop function according to safety category 3
- Optional pushbutton or joystick transmitter units
- Wireless control also available via infrared



Perfect combination

DEMAG KBK AND HOIST UNITS

BROAD CHOICE OF ATTACHMENTS TO HANDLE SPECIFIC LOADS

The right combination of crane and hoist unit is decisive for the safety and effectiveness of any lifting operation. Besides their weight, shape and material, individual requirements need to be considered in order to pick up, transport and position loads safely and reliably.

A wide range of series load handling attachments are available for standardised loads. Together with Demag KBK and a hoist unit that is optimised for your application, they offer a safe and reliable solution for both workers and materials.

HANDLING SOLUTIONS TO SAFELY PICK UP:

- sheet and plate metal
- pallets
- round and square materials
- barrels
- pipes and tubes
- packages
- boxes
- and much more

Unique workpieces and processes require specific solutions. We can design and manufacture special clamps and grippers that are tailored to meet your individual needs and support your production processes.



41616



41617



41615-1

Box clamps for handling standard boxes

90° (centre) and 360° (right) rotating clamps with spindle adjustment and self-locking drive

Demag KBK product configurator

You can configure a KBK system to meet your specific needs quickly and easily in just a few steps with our online planning tool. You always receive the best possible solution for your requirements with reliable and plausible results.

YOUR BENEFITS:

- Easy to use
- Specify products to meet your needs
- Save your configuration
- Immediate results:
 - Product description
 - Technical data
 - CAD geometry data
 - Circuit diagrams
 - Documentation
- Online ordering via Demag Shop



Simple planning

Service

Demag works with a global network of partners – including partners near to you. You benefit from innovative service from our partners to cover the entire life cycle of your equipment. The same applies to cranes, hoists, load handling attachments and related components.

Our goal is to enable you to concentrate fully on your core business by giving you the certainty that your equipment operates reliably, efficiently and without any faults or malfunctions.

Our partners are service specialists and are always ready to help you with support and advice: from planning the assembly of your KBK system to installation and acceptance approval as well as regular statutory inspections. Their service engineers are extensively trained and receive continuous further training to maintain their qualifications. The result is extremely high-quality service from a single source and near to you.





There is a solution for everything ...

... but the best one can only be found with experience

40976-11

The best solution for all your needs

From simple workshop cranes to highly complex material flow systems, Demag KBK is a tried-and-tested solution that offers smooth operating characteristics for virtually any requirement.

Benefit from our many years of experience. Our expertise in complex production and operating processes is unmatched in the industry.

Combined with the largest range of standardised light crane system products on the market, the best material transport systems can be created to meet all your needs. These systems help our customers all over the world to succeed and grow their business in future.

We call that: **more than 60 years of experience for state-of-the-art solutions.**

Find out more about KBK expertise on the following pages.

Kuhn Group

Monswiller, France

CUSTOMER REQUIREMENTS

- **Complete intralogistics solution:** equipping a new production workshop with flow production for large agricultural machinery
- Overhead handling by a **versatile and modular** transport system
- **Ergonomic** workstations for assembly

DEMAG SOLUTION

- **Area-wide** crane equipment for logistics areas and assembly lines with 3.2 km of KBK profile sections in total
- **Ergonomically controlled** single and double-girder cranes for all work steps along the 100 m-long and 25 m-wide assembly lines

RESULT

- **Precisely configured:** precise design of cranes and hoists (two-stage/ininitely variable) for the individual workstations
- **Growing installation:** thanks to its modular construction kit system, Demag KBK can be flexibly adapted to meet future requirements



**Flexible material flow
with a modular system**

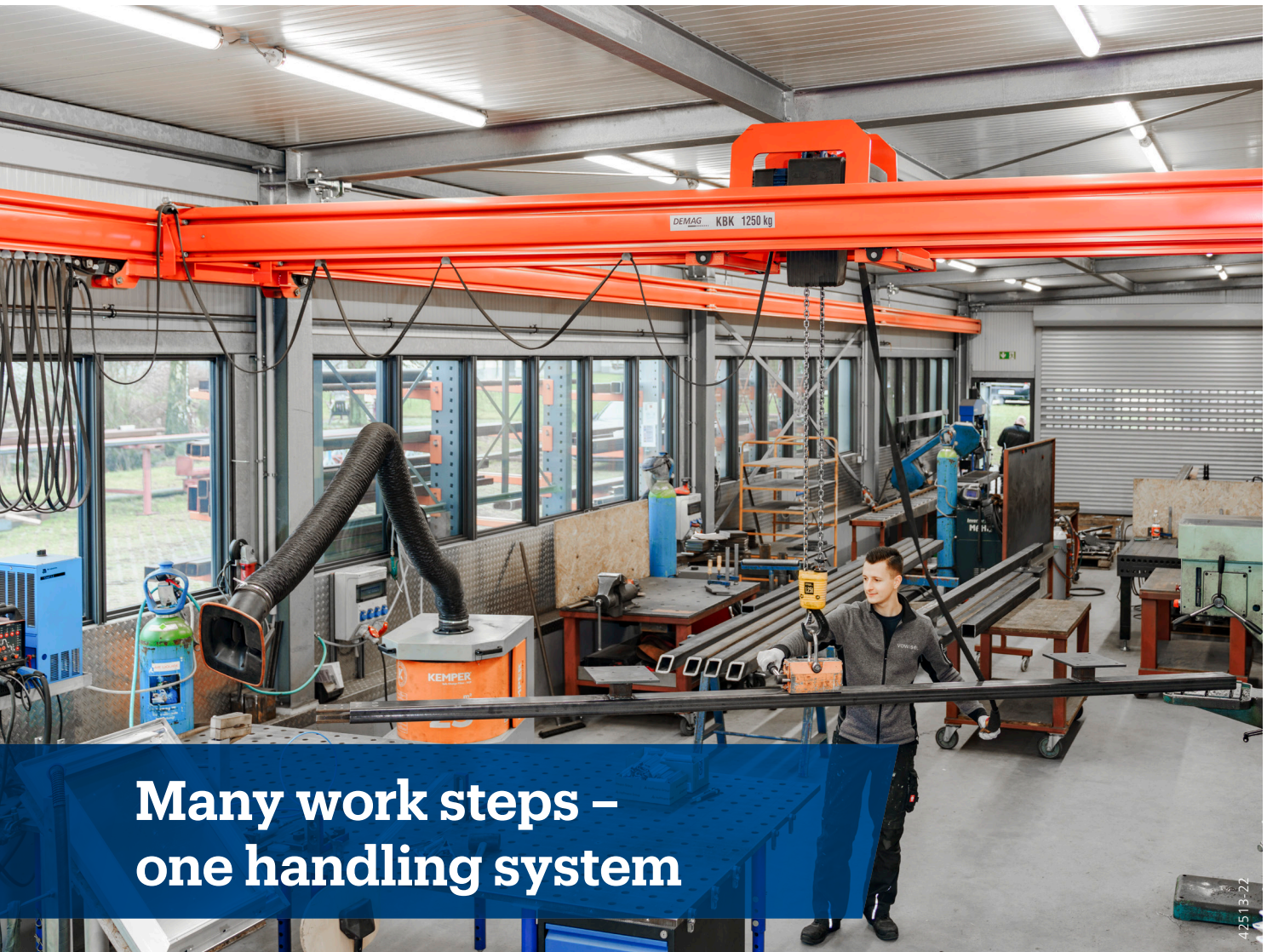

Many work steps – one handling system

Vowisol Wintergärten Radeberg, Germany

CUSTOMER REQUIREMENTS

- **Safe and reliable handling** of long goods in a production facility with limited headroom
- Installation of a **universal and versatile** transport system
- **Ergonomic** work steps with an all-in-one system

DEMAG SOLUTION

- **Extremely smooth-running suspension crane system** with 24.5 m track length for horizontal load transport
- Double-girder crane design with Demag DC-Com 1,250 kg chain hoist

RESULT

- **Optimum utilisation** of the workshop height thanks to raised crane bridges on the KBK double-girder crane and height-optimised travelling hoist
- **Space-saving overhead system:** safe and reliable movement of long goods by one person
- **Convenient operation** of the system thanks to ergonomic pendant controller

Hawe Hydraulik

Munich, Germany

CUSTOMER REQUIREMENTS

- Ergonomic workplace design improves the working climate and productivity
- Smooth-running, manually controlled crane systems for assembly processes
- Use of a modular crane system for adaptation to future production layouts

DEMAG SOLUTION

- Configuration of lightweight, ergonomic suspension cranes with KBK Aluline profile sections
- Installation of cranes on the workshop ceilings

RESULT

- **User-friendly, ergonomic solutions** for the assembly stations: cranes moved with very little effort
- **Visually appealing integration** into a bright production environment
- **Simple integration** of new or replacement of existing units possible at any time with ease



100% ergonomics

Karl Wagenaar

Velbert, Germany

CUSTOMER REQUIREMENTS

- Safe, reliable and timely supply of 26 die-casting machines with liquid zinc

DEMAG SOLUTION

- **Precisely planned and designed** for the local conditions: installation of an 87 m-long suspension monorail circuit made of KBK II-R profile sections with internal conductors
- Two manually driven travelling hoists with transport furnaces featuring a safe electric power supply

RESULT

- **Ergonomic solution:** smooth travel of the monorail hoists
- **Constant temperature of the transported goods:** energy supply to the transport furnace via internal conductors in the profile sections
- **Additional safety** thanks to elimination of trailing cables
- **Future-proof solution** thanks to modular system design, retrofitting possible – also as an automated solution

Precision and ergonomics in die-cast zinc





Safety during transport and installation

Schmitz Cargobull Vreden, Germany

CUSTOMER REQUIREMENTS

- Transport of brake lines as part of chassis flow production: from pre-assembly to installation site
- Horizontal overhead handling of up to 4 m-long, complex units
- Integration of the radio-controlled system into the customer's radio concept

DEMAG SOLUTION

- Brake lines picked up with Demag KL-DC double chain hoist and 4 m-long end carriage
- Horizontal transport over 7 m with KBK single-girder crane, electric travel via friction-wheel travel drive

DEMAG SOLUTION

- **High precision** in lifting and lowering operations due to mechanical synchronisation of the load hooks
- **Optimum use** of the low headroom thanks to low-headroom travelling hoist design with low C-dimension
- **Maximum efficiency** thanks to electric drive solutions in all 3 motion axes
- **Safe solution** thanks to safety-related cut-off of the chain hoist in the highest and lowest limit positions to avoid load sway



The technology leader working for you.

We are a world leader for light crane systems.

Our teams are recognised as the most experienced in the industry. The Demag KBK light crane system is considered to be one of the best modular crane systems in the world.



41594

SUCCESS FOR GOOD REASON

No other system has been on the market as long, no other system can combine so much experience with constant improvement based on continuous research and development. The Demag KBK system production process is always state-of-the-art. And we test our crane systems under the most punishing conditions before they leave the factory. The same also applies to KBK Aluline – the trolleys alone have run tests of 2,500 kilometres.

MAXIMUM SAFETY, QUALITY AND RELIABILITY

The Demag network of partners means you have the right specialist to ensure the long-term safety, reliability and availability of your KBK installation. Our experienced partners offer you a wide range of valuable services to cover the entire life cycle of your equipment. And the same applies to cranes, hoists, load handling attachments and related components of our Demag brand and to products supplied by other manufacturers.

MORE THAN 60 YEARS OF EXPERIENCE FOR STATE-OF-THE-ART SOLUTIONS

In 1963, we created a new crane segment with our Demag KBK crane construction kit, which revolutionised the market for cranes. The modular light crane system changed production processes in virtually all sectors of industry. It made them safer, more profitable and, for the first time, offered our customers maximum modularity, flexibility and operator ergonomics, marking the beginning of a unique success story. Our experience gained over more than 60 years of the KBK system ensures that you are provided with unmatched expertise for safe, reliable, efficient and state-of-the-art material transport solutions.

OUR GOAL

You can concentrate fully on your core business – since you have the certainty that your equipment operates reliably, efficiently and without any faults or malfunctions.

We give you everything you need: a large global service network, highly trained service engineers and a highly efficient spare parts logistics system.



0324 EN/DE 208 384 44 701 IS 152
Subject to change. No liability for errors or omissions.
Printed in Germany D310324/PDF

DEMAG CRANES & COMPONENTS GMBH

Wetter site

Ruhrstrasse 28

58300 Wetter, Germany

E info@demagcranes.com

T +49 2335 92-0

F +49 2335 92-7676

www.demagcranes.com

DEMAG